

ARCHITECTURAL SUN CONTROL



HOME OF OXYGEN

Duco Ventilation & Sun Control provides every building with a healthy supply of oxygen. With a comprehensive range of innovative natural and mechanical ventilation systems, either combined with external solar shading or otherwise, Duco offers the ultimate guarantee of a healthy and comfortable indoor climate. The occupant's health is,

therefore, central to Duco. A well-thought-out combination of basic ventilation, mechanical extraction, purge ventilation and solar shading ensures optimum air quality. Duco provides an innovative solution for residential buildings, offices, schools or care centres where everyone feels at home.

Duco, Home of Oxygen

DUCO
Ventilation & Sun Control

GENERAL 5

PRODUCTS 9

DUCOSUN

General info & DucoSun C / CF / D systems 9
DucoSun 100 C / 100 D 11
DucoSun 150 CF / 150 D 13

DucoSun Ellips 17
DucoSun Cubic 21
DucoSun Linear 23
DucoSun Wing 27
Span tables 28

DUCOSLIDE

General info & DucoSlide Systems 34
DucoSlide LuxFrame 40/40 38
DucoSlide LuxFrame 40/80 & 45/130 40
DucoSlide LuxFrame 5/40 & 5/80 44

SERVICE 47



DISCLAIMER

Illustrations in this catalogue may differ from actual product. Printing errors and/or changes excepted. Duco reserves the right to amend this information at any time. The information stated is valid as at 08.07.2019 and may be subject to changes in legislation.

DucoSlide LuxFrame

SCHEVENINGEN (NL)



ARCHITECTURAL SOLAR SHADING: FUNCTIONAL AND AESTHETIC

Now that we are making buildings even more airtight, using thicker insulation materials and the number of hot days is increasing noticeably every year, the search for alternatives to keep indoor temperatures under control is more than ever a 'hot topic'. Do you want to counteract the warming of your building as much as possible in a natural and energy-efficient way, and preferably as aesthetically as possible?

Forget white roofs, sunproof glazing or (roller) blinds, and choose **architectural solar shading** - in combination with intensive ventilation - to guarantee the best result. Thanks to Duco's extensive range featuring fixed and movable louvre blades, discrete and striking designs, plus horizontal and vertical lines, you can ensure that your project will always achieve the full effect both **functionally and aesthetically**.

This is because Duco's external solar shading systems not only give the façade a unique touch, they also provide efficient screening from the sun's rays and maintain the view outside, while preserving daylight and privacy. The result? A reduction in the cooling load of up to 63% and a significant drop in temperature. Architectural solar shading is therefore an excellent investment that will quickly pay for itself!

**DROP
TEMPERATURE
UP TO 12%**

**DROP
COOLING LOAD
UP TO 63%**

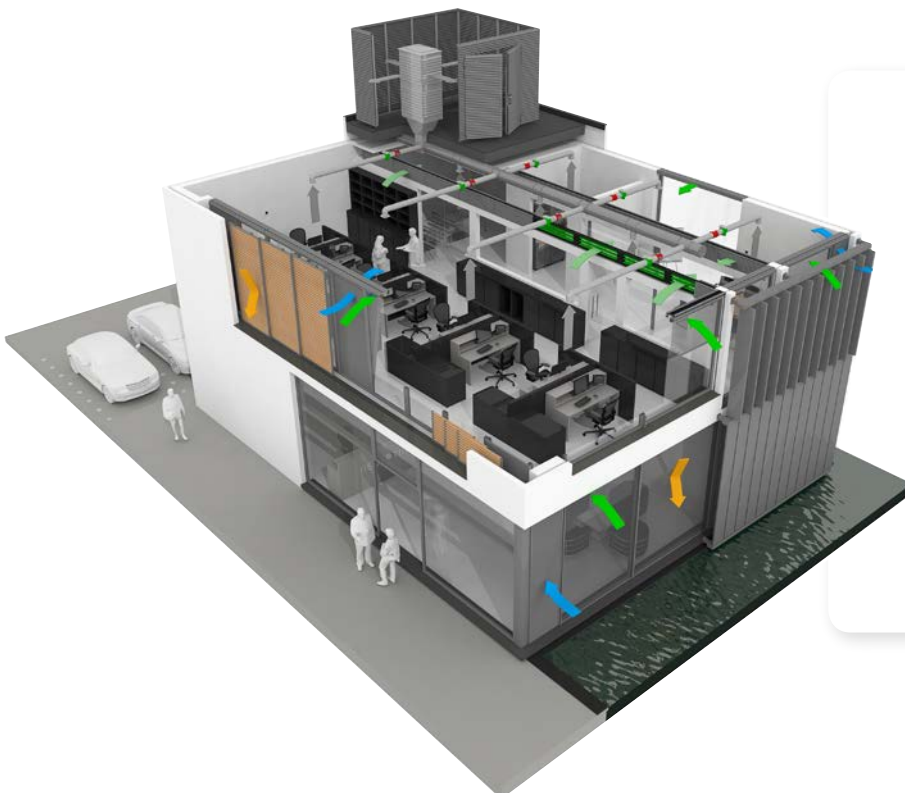

→ Total solutions

Together with natural day-time ventilation and intensive (night-time) ventilation, architectural solar shading systems are a key component of the **complete Duco concept**, which embrace both residential and non-residential buildings. This always creates an optimum living environment. See our brochures for more information.

DUCOSUN

STRUCTURAL SOLAR SHADING

With Duco's solar shading, there are numerous options. There are systems with fixed and adjustable louvre blades, discrete and striking designs, and horizontal and vertical lines.

Your ultimate choice of solar shading system will depend on your available budget and the technical possibilities, and of course on your personal taste. But whatever system you choose: Duco guarantees an optimum balance between as little heat from the sun as possible and as much daylight as possible.

→ DucoSun C / CF / D

External solar shading systems in which the aluminium louvre blades are locked into place on plastic blade holders. These are firstly secured into place on the aluminium support profile using Duco's patented 'Slide-Click' system. Choose from three different types of louvre blade: C, CF or D.

Material

- **Aluminium:** EN AW – 6063 T66
- **Surface treatment:**
Anodised in natural as standard (15-20 µm) (VB6/A20/VOM1)
Enamelled polyester powder coating (60-80 µm)
- **Plastic parts:**
Polyamide, glass fibre-reinforced, UV colourfast



100C louvre blade



150CF louvre blade



100D louvre blade



150D louvre blade

Ellips louvre blade



Cubic louvre blade



Linear louvre blade



Wing louvre blade



→ DucoSun Ellips / Cubic / Linear / Wing

External solar shading systems in which the aluminium louvre blades are mounted on the support structure so as to be fixed or adjustable. The sleek lines of the blades create a particularly attractive result. Choose from four different types of louvre blade: Ellips, Cubic, Linear and Wing.

Material

- **Aluminium:** EN AW – 6060 T66
- **Surface treatment:**
Anodised in natural as standard (15-20 µm) (VB6/A20/VOM1)
Enamelled polyester powder coating (60-80 µm)

INSTALLING THE SYSTEMS

→ Horizontally

Horizontally installed solar shading systems keep the heat out at warmer times of the year (May-September), while allowing the heat from the low sun in during the colder months (October-April). This ensures optimum energy gain.



→ Vertically

Vertically installed solar shading systems offer maximum privacy while maintaining the view outside. With vertically installed solar shading systems the space can be darkened.

With vertically installed systems of the types DucoSun Ellips, DucoSun Cubic and DucoSun Linear, the louvre blades can be fitted both horizontally and vertically.

TESTING STRENGTH

The strength of external solar shading systems can best be determined with wind tunnel tests, which generate maximum air flows. Duco has its solar shading systems tested at the von Karman Institute in Brussels, a leading international independent organisation for high-tech research into fluid dynamics.

All the DucoSun systems in this brochure have been tested in Duco's laboratory and at the von Karman Institute. Duco also developed software for producing strength calculations.

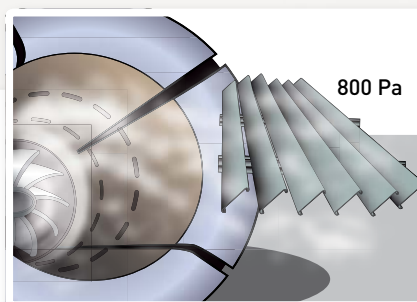

→ Finish

Each type of solar shading is available in any colour: **F1, any RAL colour, textured paint, special paints/lacquers, etc.** Each type of solar shading in this folder satisfies the **Qualicoat** and **Qualanod** specifications



Cegelec



DUCOSUN C / CF / D SYSTEMS

External solar shading systems in which the aluminium louvre blades are locked into place on plastic blade holders. These are firstly secured into place on the aluminium

support profile using Duco's patented **Slide-Click system**. Choose from three different types of louvre blade: C, CF or D.

Underslung

Fitting: Blades below the support profiles

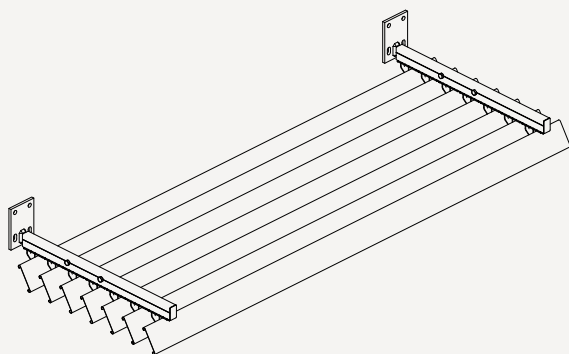

Overlung

Fitting: Blades above the support profiles

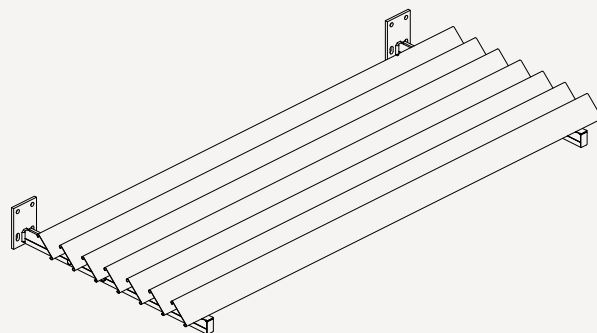

Intermediate

Fitting: Blades between the support profiles

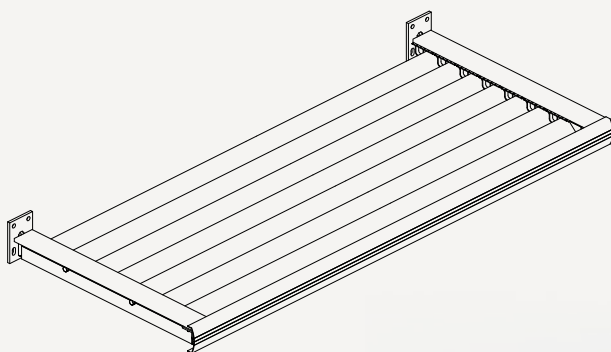

Framed

Fitting: Blades in a frame profile

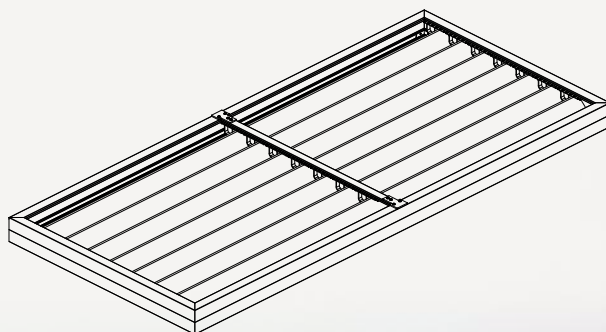

Vertically

Fitting: Blades vertical, solar shading in the surface of the façade

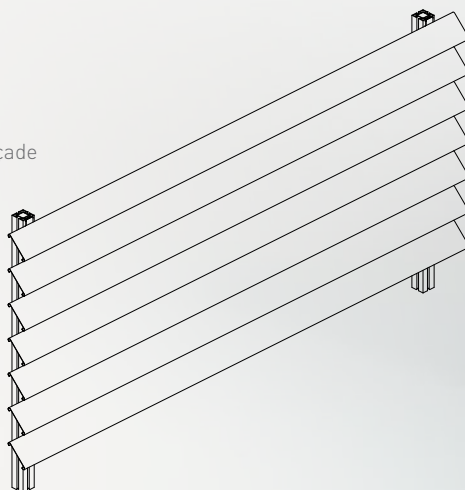

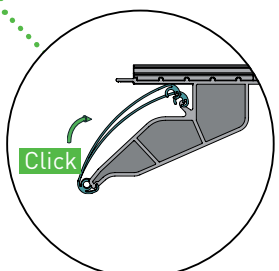
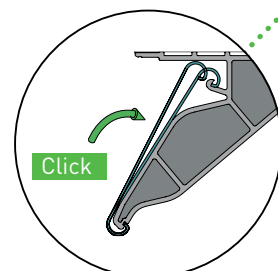
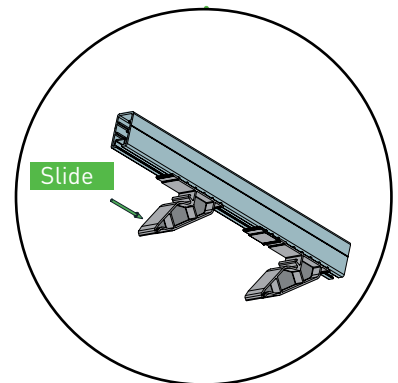
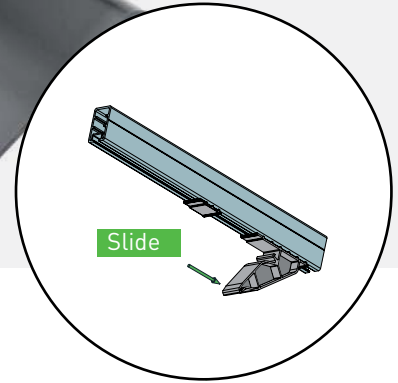

100C

100D

Slide-click
system

DucoSun 100 C/100 D

Solar shading with discrete 'C- or D-shape' louvre blades

DucoSun 100 C/100 D is an architectural system consisting of modular components with fixed C- or D-blades. Thanks to the patented Duco "Slide-Click" system, the louvre blades are secured quickly and easily in a fixed angle to the support structure.

- Simple component system.
- Louvre blades with discrete C- or "elliptical" D-design.
- Quick assembly thanks to the patented "Slide-Click" system.
- Large span possible with the 100 D louvre blade.
- Specific assembly application in any technical construction situation.
- 100 D louvre blades can be finished with end plates.

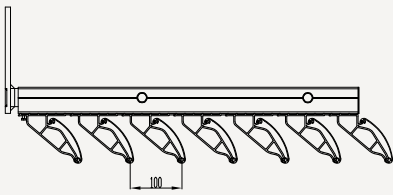

DucoSun 100 D
Underslung

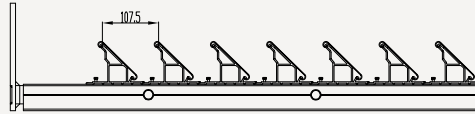

DucoSun 100 C
Overslung

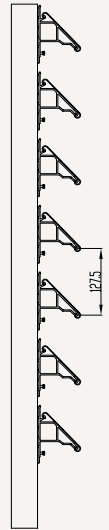

DucoSun 100 C
vertically

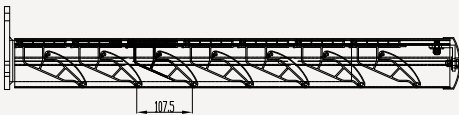

DucoSun 100 D
Intermediate

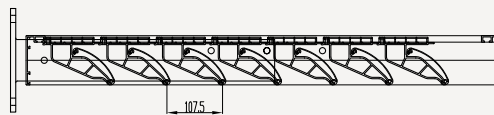

DucoSun 100 D
Framed

Summary table for DucoSun 100 C / 100 D

	Louvre blade end piece	Louvre blade spacing	Inclination	Finishing options:		
Underslung	ALU side plates possible with louvre blade 100 D	100 mm	60°	plastic stopper	or	decorative profile: 150 flat, 175 flat or 90 round
Overslung	ALU side plates possible with louvre blade 100 D	107.5 mm	45°	plastic stopper	or	decorative profile: 150 flat, 175 flat or 90 round
Intermediate	-	107.5 mm	45°	with decorative frame: 100 semicircular		
Framed	-	107.5 mm	45°	with frame profile: 100 round or 100 flat		
Vertically	ALU side plates possible with louvre blade 100 D	127.5 mm	45°			

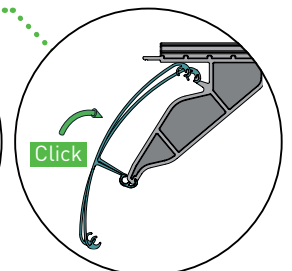
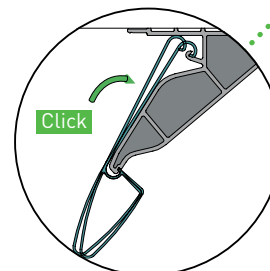
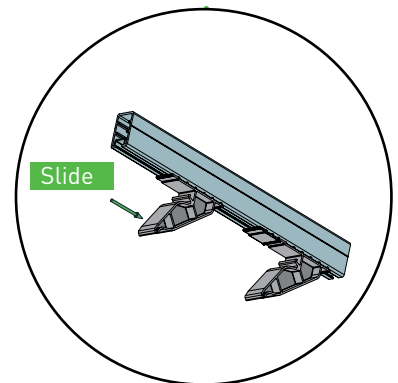
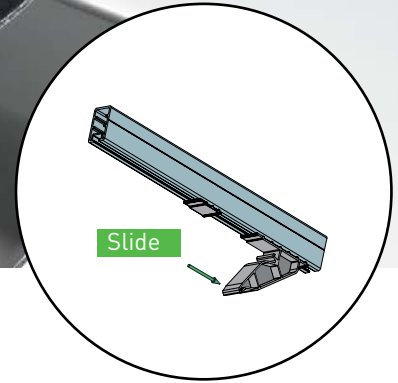

150CF

150D

Slide-click system

DucoSun 150 CF/150 D

Solar shading with 'elliptical' louvre blades

DucoSun 150 CF/150 D is an architectural system consisting of modular components with fixed louvre blades. Thanks to the patented Duco "Slide-Click" system, the louvre blades are secured quickly and easily in a fixed angle to the support structure.

Louvre blades types 150 CF and 150 D combine the functional benefits of the basic 100 C blade with the attractive, elliptical design of the DucoSun Ellips blade. The louvre blades are particularly strong. This allows a greater span and fewer support profiles are needed.

- Simple system with modular components.
- Louvre blades with attractive, "elliptical" design.
- Quick assembly thanks to the patented "Slide-Click" system.
- Just like the 150 D louvre blade, the strength of the "CF" blade allows a large span.
- Large blade spacing (distance between 2 blades).
- Specific assembly application for any situation.
- 150 D louvre blades can be finished with end plates.

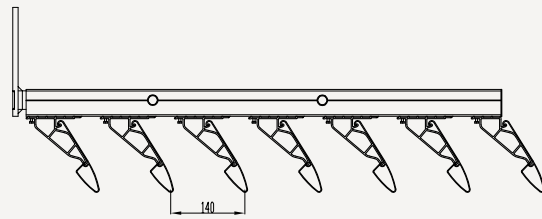

DucoSun 150 CF
Underslung

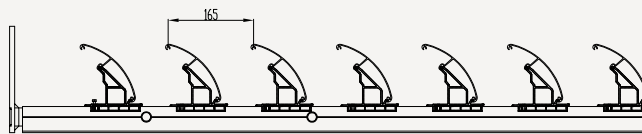

DucoSun 150 D
Overslung

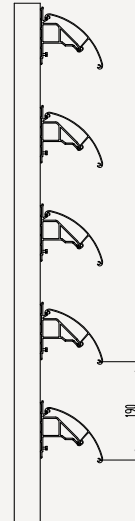

DucoSun 150 D
vertically

Summary table for DucoSun 150 CF / 150 D

	Louvre blade end piece	Spacing Louvre	Inclination	Finishing options:	
Underslung	-Plastic stopper for 150CF louvre blade - ALU side plates possible with 150 D louvre blade	140 mm	60°	plastic stopper	or decorative frame: 90 round
Overslung	-Plastic stopper for 150CF louvre blade - ALU side plates possible with 150 D louvre blade	165 mm	45°	plastic stopper	or decorative frame: 90 round
Vertically	-Plastic stopper for 150CF louvre blade - ALU side plates possible with 150 D louvre blade	190 mm	45°	-	-





DucoSun Ellips

Ternat (BE)





DucoSun **Ellips**

Solar shading with a choice of seven elliptical louvre blades

This solar shading system is available with **fixed or electronically adjustable louvre blades**. These are installed on site to the support structure (horizontal or vertical). Here, many different angles are possible. This enables the system to provide the optimum shade, irrespective of the glass surface area and irrespective of where the sun is coming from.

The elliptical louvre blades ensure the **maximum amount of diffused daylight**. They are available in seven sizes: 100 – 150 – 200 – 250 – 300 – 350 – 400. DucoSun Ellips gives the architect a wide choice in the design.

- The elliptical louvre blades ensure the maximum amount of diffused daylight.
- Compact assembly ensures optimum shading.
- Choice of 7 louvre blade types.
- Wide range of assembly applications.

BASIC COMPONENTS

- Louvre blades

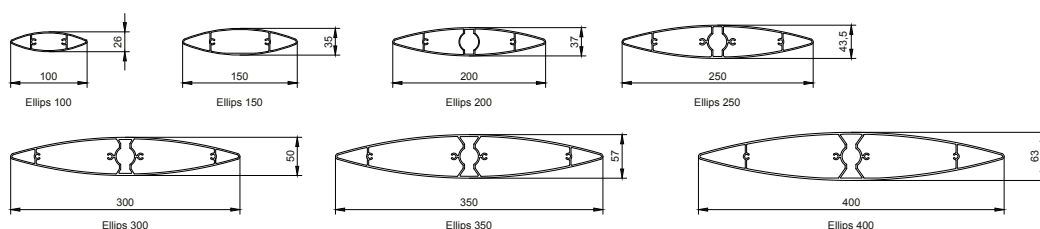

SYSTEMS

Intermediate

Fitting: Horizontally
Fixed overhanging canopy with project-related wall and side plates

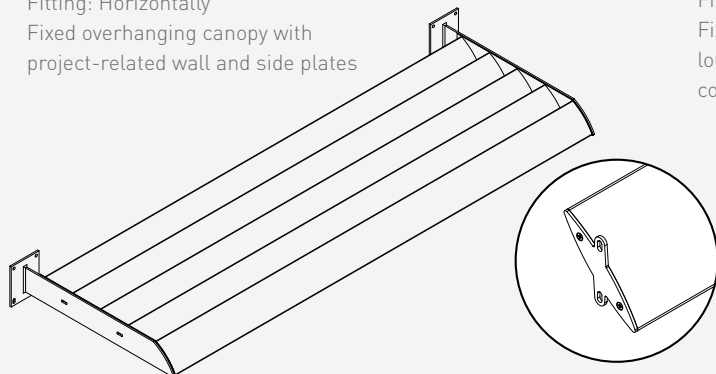

Standard side plates also available

Fitting: Horizontally
Fixed module with horizontal louvre blades and project-based composite plates

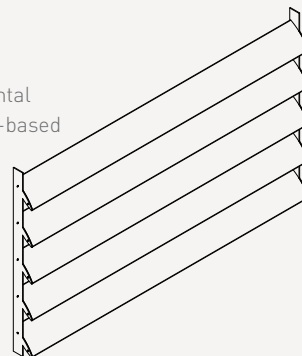

Unifit

Fitting: Vertically
Horizontal louvre blades in a fixed bracket ensure a continuous façade view

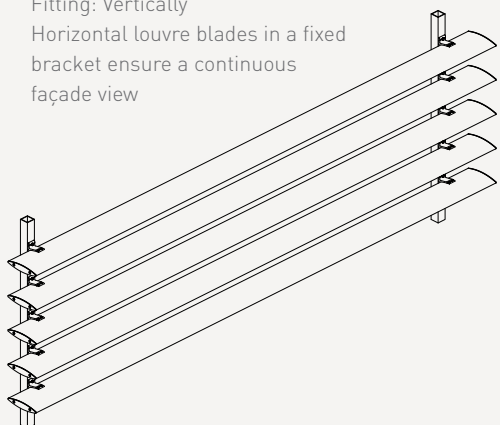

Multifit

Fitting: Vertically
Horizontal louvre blades in a base and bracket ensure a continuous façade view

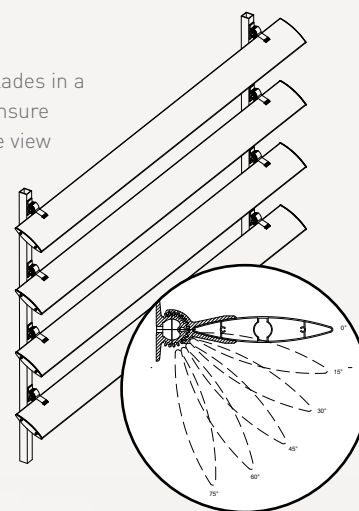

#angles of inclination

Adjustable

Fitting: Vertically
Electronically operated louvre blades in horizontal or vertical position

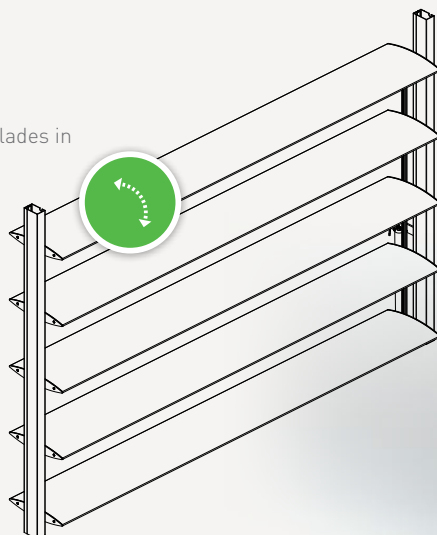

DucoSun Cubic

Roeselare (BE)







DucoSun **Cubic**

Solar shading with sleek, rectangular louvre blade

The DucoSun Cubic is available with fixed or electronically adjustable louvre blades. These are installed on site to the support structure (horizontal or vertical). Depending on the type, the fixed louvre blades are installed at an angle of 0° or 90°. Together with the **rectangular form** of the louvre blade this gives a particularly sleek effect. If the electronically adjustable louvre blades are closed, they have an optimum solar shading effect. The closed louvre blades and the façade surface are aligned, forming a single harmonious whole.

The rectangular louvre blades ensure the **maximum amount of diffused daylight**. They are available in five sizes: 100 - 150 - 200 - 300 and 400.

- Sleek, rectangular blade shape.
- The closed louvre blades and the façade surface are aligned, forming a single harmonious whole.

BASIC COMPONENTS

- Louvre blades

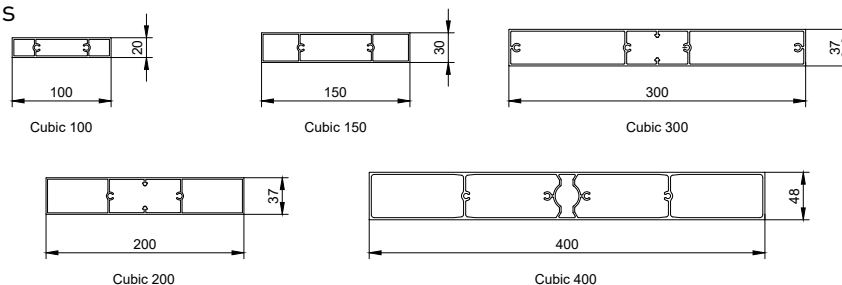

SYSTEMS

Intermediate

Fitting: Horizontally
Fixed overhanging canopy with project-related wall and side plates

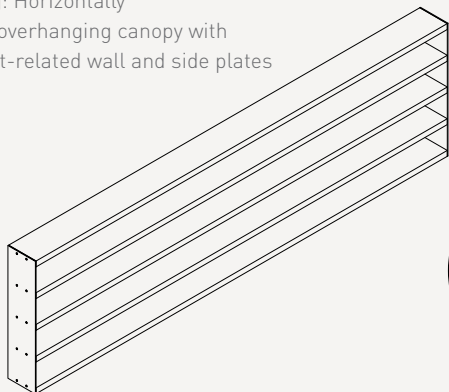

Fitting: Horizontally
Fixed module with horizontal louvre blades and project-based composite plates

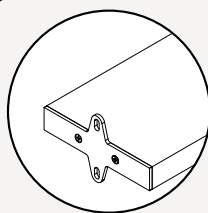
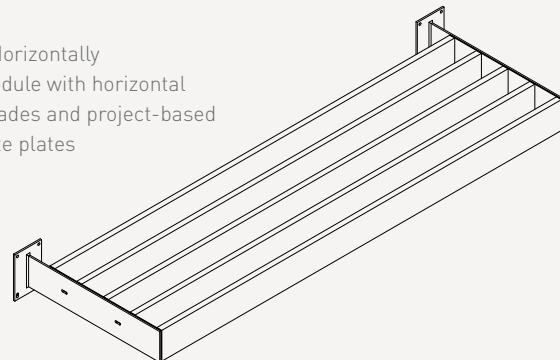

Standard side plates also available

Unifit

Fitting: Vertically
Horizontal louvre blades in a fixed bracket ensure a continuous façade view

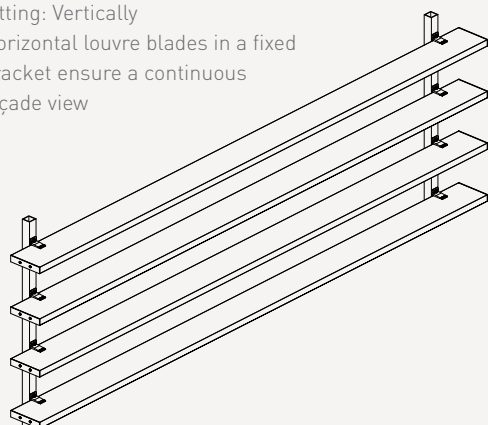

Multifit

Fitting: Vertically
Horizontal louvre blades in a base and bracket ensure a continuous façade view

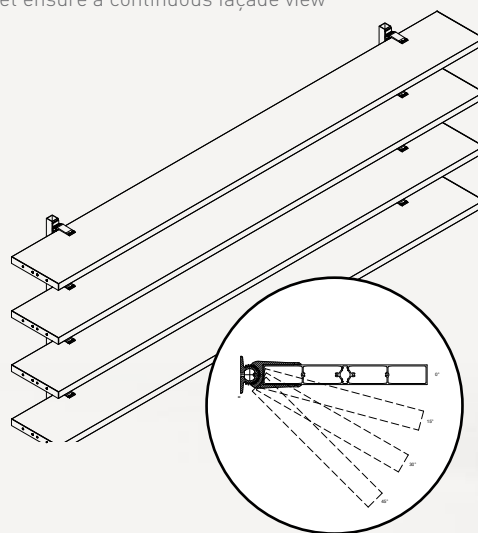

#angles of inclination

Adjustable

Fitting: Vertically
Electronically operated louvre blades in horizontal or vertical position

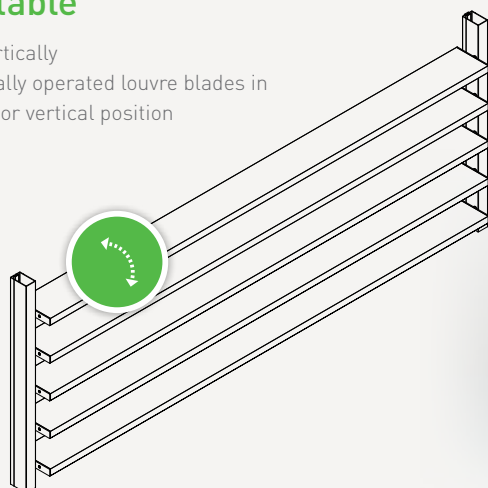



DucoSun **Linear**

Solar shading with louvre blade in the form of a parallelogram

The DucoSun Linear is available with fixed or electronically adjustable louvre blades. These are installed on site to the support structure (horizontal or vertical). The fixed louvre blades are installed at an angle of 45°. Together with the louvre blade, in the form of a parallelogram, this provides a particularly attractive effect. If the electronically adjustable louvre blades are closed, they have an **optimum solar shading effect**. The closed louvre blades and the façade surface are aligned, forming a single harmonious whole.

The parallelogram-shaped louvre blades ensure the maximum amount of **diffuse daylight**. They are available in two sizes: 200 and 300.

- Very attractive blade shape (parallelogram).
- The closed louvre blades and the façade surface are aligned, forming a single harmonious whole.
- 100% solar shading with closed blades.

BASIC COMPONENTS

- Louvre blades

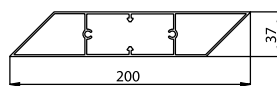

Linear 200

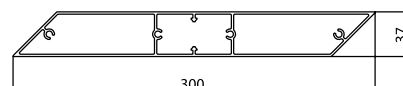

Linear 300

SYSTEMS

Intermediate

Fitting: Horizontally
Fixed overhanging canopy with project-related wall and side plates

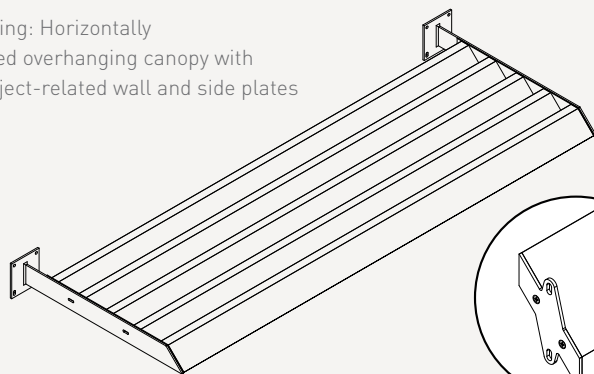

Fitting: Vertically
Fixed module with horizontal louvre blades and project-based composite plates

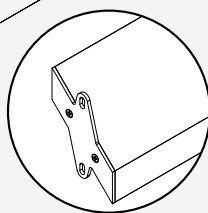
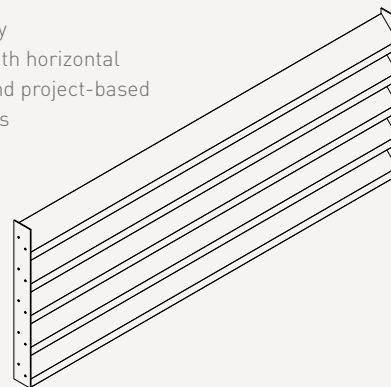

Standard side plates also available

Unifit

Fitting: Vertically
Horizontal louvre blades in a fixed bracket ensure a continuous façade view

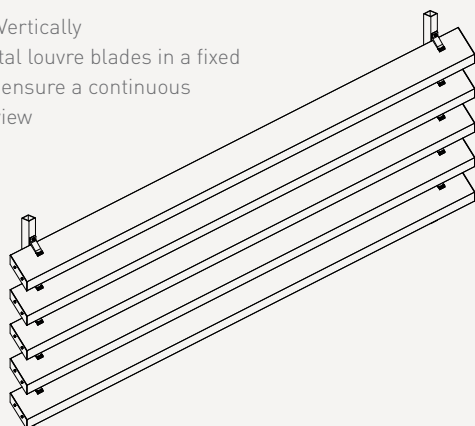

Adjustable

Fitting: Vertically
Electronically operated louvre blades in horizontal or vertical position

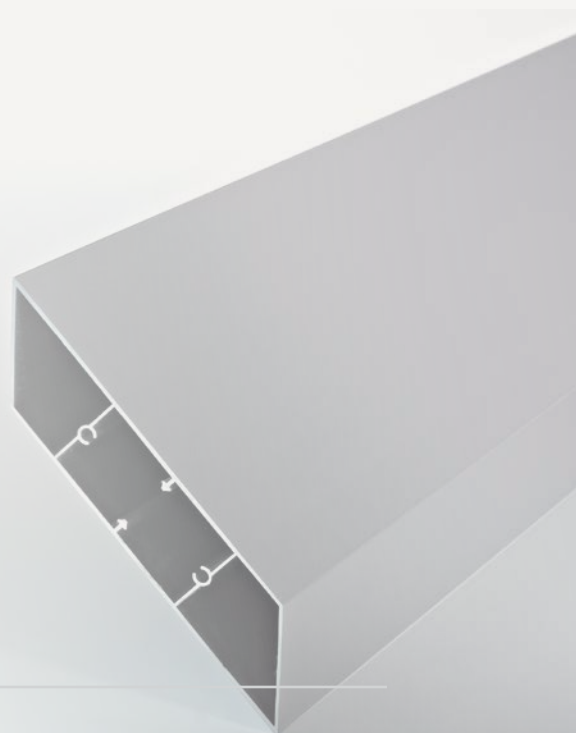
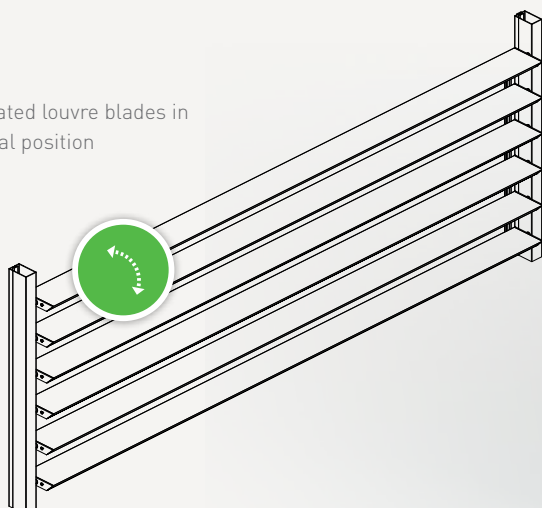

DucoSun Wing

Wijnegem (BE)





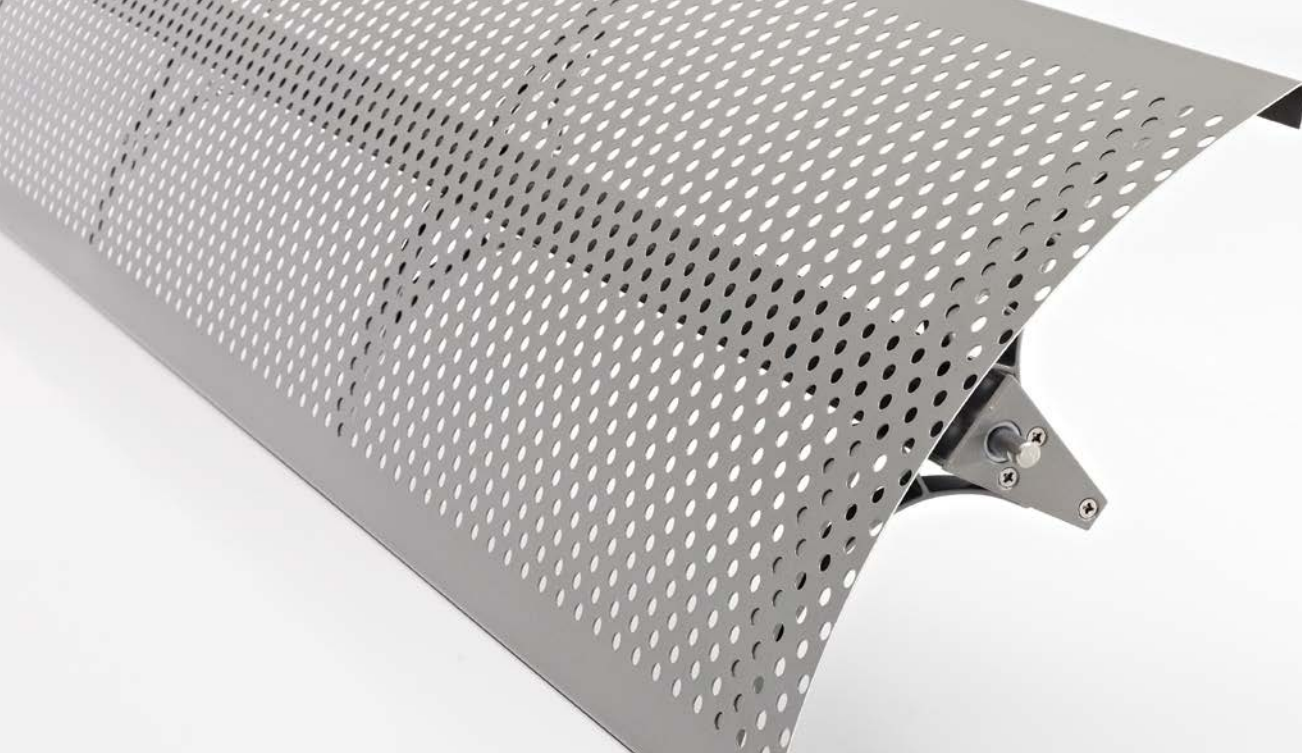

DucoSun **Wing**

Solar shading with fin-shaped louvre blade

The DucoSun Wing is perforated and thus assures perfect harmony between solar shading and shadow. The fin-shaped louvre blade provides a **great design statement** and, in addition to the standard perforation, is also available in other perforations on request.

The adjustable system can be **installed horizontally as well as vertically**, thus guaranteeing a maximum level of privacy with an adequate view of outside for every project.

- Large perforated fin-shaped louvre blade (500 mm and 600 mm)
- Optimum balance between sunlight and shading
- Movable system

BASIC COMPONENTS

- Louvre blades

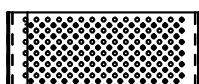
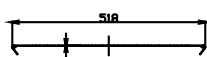

Wing 500 louvre blade
Perforated Ø 10 mm

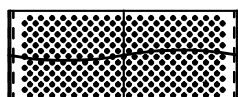
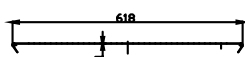

Wing 600 louvre blade
Perforated Ø 10 mm

SYSTEMS

Adjustable

Fitting: Vertically
Electronically operated louvre blades
in horizontal or vertical position

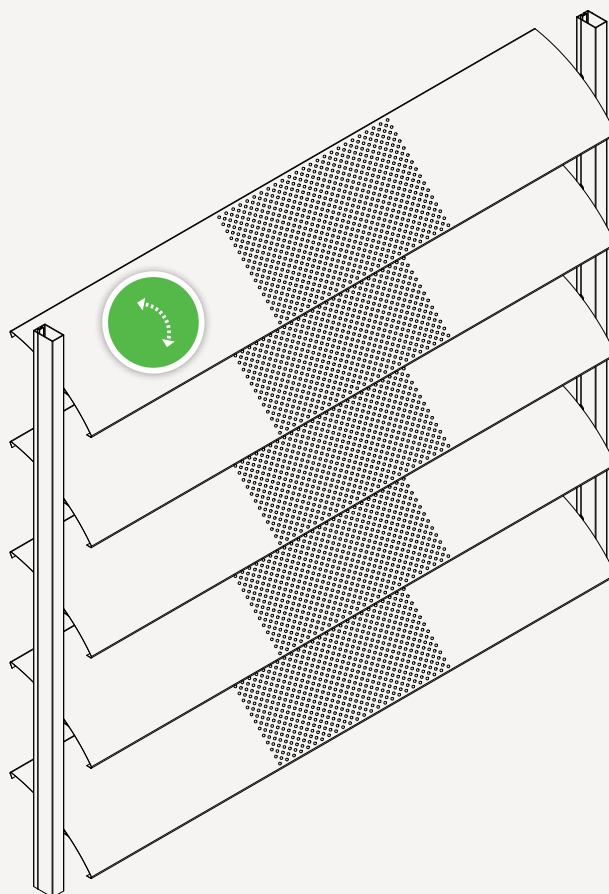

MAXIMUM SPAN FOR INTERMEDIATE SYSTEMS:

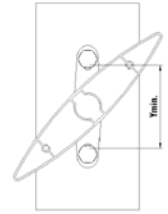

- Situation 1: Assembly of louvre between two customised composite plates. NB: value applicable to louvre blade span only, no allowance is made for strength and fixing of composite plates.
- Situation 2: Assembly of louvre with two Duco side plates between fixed structure + assembly of louvre with two Duco side plates with Duco support profile including use of Duco washers.
- Situation 3: Assembly of louvre with two Duco side plates and support section between fixed structure.

Values applicable to solar shading aligned with the window only, not applicable to projecting solar shading.

DucoSun Ellips

Louvre	Angle	Distance Ymin. (mm) <small>(cc. fastenings)</small>	Maximum span (mm) with wind load of:								
			600 Pa <small>(±115 km/h)</small>			800 Pa <small>(±130 km/h)</small>			1250 Pa <small>(±165 km/h)</small>		
			SITUA-TION 1	SITUA-TION 2	SITUA-TION 3	SITUA-TION 1	SITUA-TION 2	SITUA-TION 3	SITUA-TION 1	SITUA-TION 2	SITUA-TION 3
Ellips 100	0°	40	3200	3200	3200	3200	3200	3200	3050	3050	2850
	45°	50	3200	3200	3200	3200	3200	3200	3200	3200	3150
Ellips 150	0°	60	3900	3900	3900	3900	3900	3900	3750	3750	2900
	45°	80	3900	3900	3900	3900	3900	3900	3900	3900	3300
Ellips 200	0°	70	4050	4050	3700	4050	4050	3250	4050	3750	2650
	45°	80	4050	4050	3900	4050	4050	3450	4050	3950	3200
Ellips 250	0°	110	4300	4300	4050	4300	4300	3550	4300	4100	2900
	45°	110	4300	4300	4050	4300	4300	3550	4300	4100	2900
Ellips 300	0°	100	4600	4600	3500	4600	4350	3100	4600	3550	2550
	45°	140	4600	4600	4100	4600	4600	3600	4600	4150	2950
Ellips 350	0°	132	4900	4900	3650	4900	4550	3250	4900	3750	2650
	45°	132	4900	4900	3650	4900	4550	3250	4900	3700	2650
Ellips 400	0°	110	5250	4400	3150	5250	3900	2750	5250	3200	2300
	45°	150	5250	5100	3600	5250	4500	3200	5250	3700	2650

DucoSun Ellips Intermediate

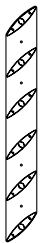

DucoSun Cubic

Louvre	Angle	Distance Ymin. (mm) <small>(cc. fastenings)</small>	Maximum span (mm) with wind load of:								
			600 Pa <small>(±115 km/h)</small>			800 Pa <small>(±130 km/h)</small>			1250 Pa <small>(±165 km/h)</small>		
			SITUA-TION 1	SITUA-TION 2	SITUA-TION 3	SITUA-TION 1	SITUA-TION 2	SITUA-TION 3	SITUA-TION 1	SITUA-TION 2	SITUA-TION 3
Cubic 100	0°	/	3250	3250	3250	3250	3250	3250	3050	3050	2850
	45°	/	/	/	/	/	/	/	/	/	/
Cubic 150	0°	69	3550	3550	3550	3550	3550	3500	3550	3550	2850
	45°	109	3550	3550	3550	3550	3550	3550	3550	3550	3550
Cubic 200	0°	70	4000	4000	3700	4000	4000	3250	4000	3750	2650
	45°	98	4000	4000	4000	4000	4000	3850	4000	4000	3100
Cubic 300	0°	90	4600	4600	3300	4600	4050	2900	4600	3350	2350
	45°	110	4600	4600	3700	4600	4600	3250	4600	3750	2650
Cubic 400	0°	130	5100	4200	3000	5100	3750	2650	5100	3100	2200
	45°	150	5100	4750	3400	5100	4200	3000	5100	3450	2450

DucoSun Cubic Intermediate

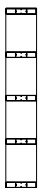

DucoSun Linear

Louvre	Angle	Distance Ymin. (mm) <small>(cc. fastenings)</small>	Maximum span (mm) with wind load of:								
			600 Pa <small>(±115 km/h)</small>			800 Pa <small>(±130 km/h)</small>			1250 Pa <small>(±165 km/h)</small>		
			SITUA-TION 1	SITUA-TION 2	SITUA-TION 3	SITUA-TION 1	SITUA-TION 2	SITUA-TION 3	SITUA-TION 1	SITUA-TION 2	SITUA-TION 3
Linear 200	0°	70	4100	4100	3700	4100	4100	3300	4100	3750	2650
	45°	80	4100	4100	4100	4100	4100	3850	4100	4100	3150
Linear 300	0°	80	4450	4450	3300	4450	4100	2900	4450	3350	2400
	45°	130	4450	4450	4000	4450	4450	3550	4450	4050	2900

DucoSun Linear Intermediate



MAXIMUM SPAN FOR UNIFIT SYSTEMS:

Permanent external solar shading system. The aluminium louvre blades are fastened at a set angle of 0°, 30° or 45° (depending on the type of blade) on aluminium support sections using a “unifit” bracket. The distance between two louvres (blade pitch) depends on the type of louvre and the angle.

Values applicable to solar shading aligned with the window only, not applicable to projecting solar shading.

DucoSun Ellips

Louvre	Unifit:		Maximum span (mm) with wind load of:		
	bracket(°)	width (mm)	600 Pa (±115 km/h)	800 Pa (±130 km/h)	1250 Pa (±165 km/h)
Ellips 100	0°	30	2650	2650	2450
Ellips 150	0°	40	3700	3500	3050
	45°	40	3700	3700	3400
Ellips 200	0°	40	3900	3750	3300
	45°	40	3950	3950	3650
Ellips 250	0°	40	4200	4200	3650
	30°	40	4300	4300	3850
	45°	40	4300	4300	4100
Ellips 300	0°	40	4500	4050	2700
	30°	40	4650	4650	3400
	45°	40	4650	4650	3400
Ellips 350	45°	50	4400	4400	3100

DucoSun **Ellips**
Unifit

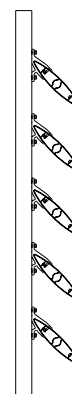

DucoSun Cubic

Louvre	Unifit:		Maximum span (mm) with wind load of:		
	bracket(°)	width (mm)	600 Pa (±115 km/h)	800 Pa (±130 km/h)	1250 Pa (±165 km/h)
Cubic 100	0°	30	3150	2950	2550
Cubic 150	0°	40	3550	3550	3300
Cubic 200	0°	40	4000	4000	3800
Cubic 300	0°	40	4400	4200	2800

DucoSun **Cubic**
Unifit

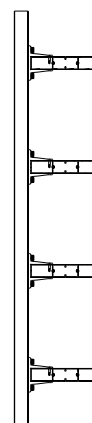

DucoSun Linear

Louvre	Unifit:		Maximum span (mm) with wind load of:		
	bracket(°)	width (mm)	600 Pa (±115 km/h)	800 Pa (±130 km/h)	1250 Pa (±165 km/h)
Linear 200	45°	40	4000	4000	4000
Linear 300	45°	40	4450	4450	3850

DucoSun **Linear**
Unifit

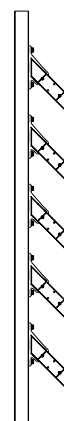

MAXIMUM SPAN FOR **MULTIFIT** SYSTEMS:

Permanent external solar shading system. The aluminium louvres are attached at a fixed angle on aluminium support sections using the patented “multifit” system. This consists of a “base” and a “bracket”. These two sections are attached by means of teeth. This makes various positions possible in steps of 15°. The distance between two louvres (blade pitch) depends on the type of louvre and the angle.

Values applicable to solar shading aligned with the window only,
not applicable to projecting solar shading.

DucoSun Ellips

Louvre	Multifit width (mm)	Maximum span (mm) with wind load of:		
		600 Pa (±115 km/h)	800 Pa (±130 km/h)	1250 Pa (±165 km/h)
Ellips 100	30	3100	2850	2450
Ellips 200	40	3900	3750	2950
Ellips 250	50	4200	3800	2500
Ellips 300	50	3500	2750	1850
Ellips 350	50	2600	2050	1450
Ellips 350	120	4800	4800	3350
Ellips 400	50	2050	1600	1100
Ellips 400	120	4950	3900	2600

Not standard

Not standard

DucoSun Cubic

Louvre	Multifit width (mm)	Maximum span (mm) with wind load of:		
		600 Pa (±115 km/h)	800 Pa (±130 km/h)	1250 Pa (±165 km/h)
Cubic 400	50	2350	1850	1300
Cubic 400	120	4900	4900	3800

Not standard

DucoSun **Ellips**
Multifit

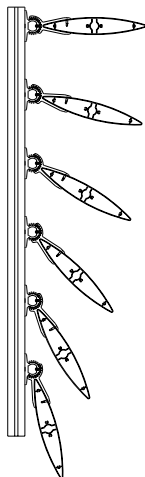

DucoSun **Cubic**
Multifit

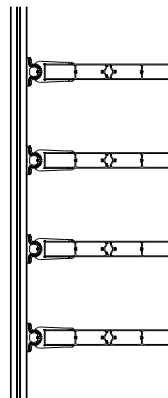

MAXIMUM SPAN FOR **ADJUSTABLE** SYSTEMS:

Values applicable to solar shading aligned with the window only,
not applicable to projecting solar shading.

DucoSun Ellips

Louvre	Maximum span (mm) with wind load of:		
	600 Pa (±115 km/h)	800 Pa (±130 km/h)	1250 Pa (±165 km/h)
Ellips 100	2250	2050	1750
Ellips 150	2900	2600	2250
Ellips 200	3100	2850	2450
Ellips 250	3300	3150	2750
Ellips 300	3600	3600	3100
Ellips 350	3850	3850	3450
Ellips 400	4100	4100	3750

DucoSun Cubic

Louvre	Maximum span (mm) with wind load of:		
	600 Pa (±115 km/h)	800 Pa (±130 km/h)	1250 Pa (±165 km/h)
Cubic 100	not permitted	not permitted	not permitted
Cubic 150	3100	2850	2450
Cubic 200	3500	3300	2850
Cubic 300	3500	3450	3000
Cubic 400	3950	3950	3700

DucoSun Linear

Louvre	Maximum span (mm) with wind load of:		
	600 Pa (±115 km/h)	800 Pa (±130 km/h)	1250 Pa (±165 km/h)
Linear 200	3450	3150	2700
Linear 300	3450	3350	2900

DucoSun Wing

Louvre	Maximum span (mm) with wind load of:		
	600 Pa (±115 km/h)	800 Pa (±130 km/h)	1250 Pa (±165 km/h)
Wing 500	4650	4250	3750
Wing 600	4550	4150	3400

Table is valid for perforated louvres.

DucoSun **Ellips**
adjustable

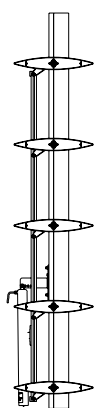

DucoSun **Cubic**
adjustable

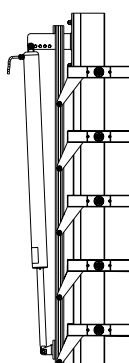

DucoSun **Linear**
adjustable

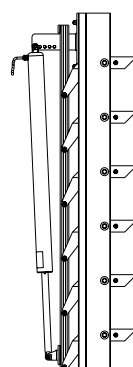

DucoSun **Wing**
adjustable





6 HOURS OF
WEC SPA-FRANCORCHAMPS
10 APRIL - 11 MAY 2016
WEC

WILD GEES

ZONE
P

DucoSlide Wood

Brussels (BE)



DUCOSLIDE

ALUMINIUM SLIDING PANELS

Duco also developed architectural solar shading in sliding panels. The DucoSlide range consists of aluminium frames holding wooden or aluminium louvre blades. Thanks to the wide selection of louvre blades, the architect or client always has a large choice that will undoubtedly fit any project. In addition, these frames can be moved either manually or electronically.

the aluminium frames can slide completely across the windows on a rail, for an optimum balance between shading and daylight. Thanks to the different sliding systems -simple, symmetrical, telescopic or BiFold- the panels can also be slid completely away from the window.

→ DucoSlide LuxFrame

External solar shading systems in which the aluminium louvre blades are attached to a frame. Choose from three different types of louvre blade:



40/40 frame profile



40/80 frame profile



45/130 frame profile

→ DucoSlide SlimFrame

External solar shading systems in which the aluminium louvre blades are secured between discrete side profiles.



5/40 frame profile



5/80 frame profile

→ Operation

All types of DucoSlide in this brochure can be operated both manually and electronically (except Bifold). Contact Duco for more information.

Duco has a new adjustable system for coping with variable heights, the 'Vario'



→ Material

- **Aluminium:** EN AW – 6060 T66
- **Surface treatment:**
 - Anodised in natural as standard (15-20 µm) (VB6/A20/VOM1)
 - Enamelled polyester powder coating (60-80 µm)

→ Dimensions

The maximum dimensions of the frame of the DucoSlide sliding panels depend on the type used, as well as the specific project. Contact Duco to determine the dimensions for your project.

→ single sliding system

Independently operated individual panels.

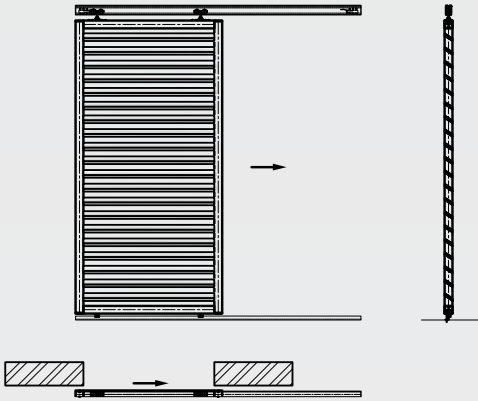

→ Symmetrical sliding system

Two connected panels that slide symmetrically away from or towards each other

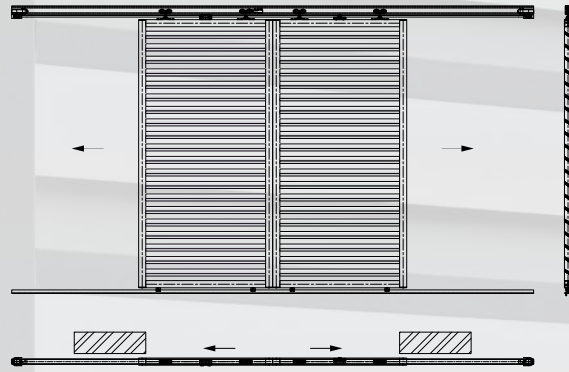

→ Telescopic sliding system

Two or three panels linked together in succession that extend telescopically.

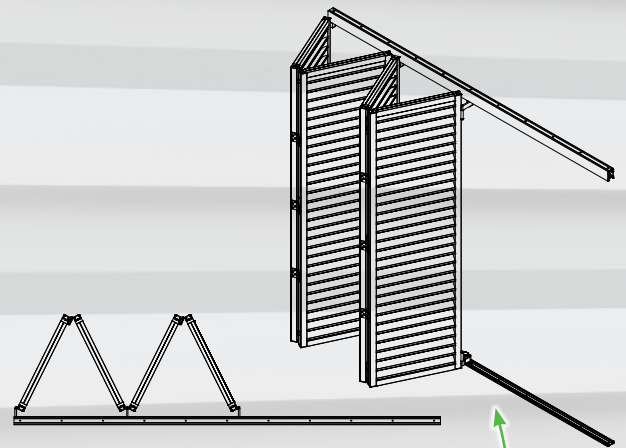

→ BiFold/QuadraFold folding system

Two or four folding panels are integrated into a whole that can be slid fully away. This creates a clear-cut aesthetic difference between the open and closed positions.

→ Finish

Each type of solar shading is available in any colour: **F1, any RAL colour, textured paint, special paints/lacquers, etc.** Each type of solar shading in this folder satisfies the **Qualicoat** and **Qualanod** specifications





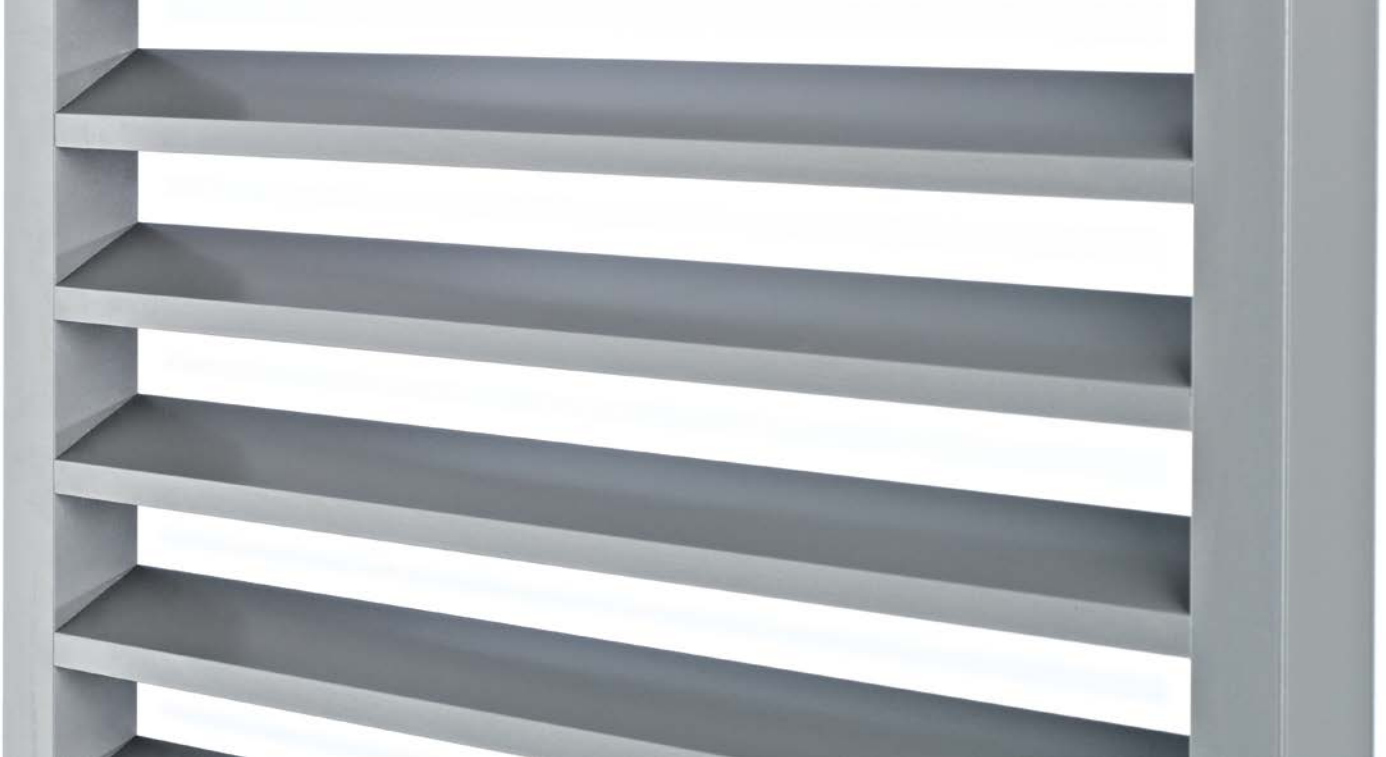

DucoSlide **LuxFrame**

(40/40 frame profile)

The DucoSlide LuxFrame 40/40 is a permanent external solar shading system with sliding panels. In this type, the different louvre blades are incorporated into a robust frame profile.

Frame types

→ DucoSlide LuxFrame with 40/40 frame profile and fixed louvre blades

Sliding systems

→ Single, symmetrical or telescopic

Folding systems

→ BiFold and QuadraFold

- Maximum degree of privacy.
- Various louvre blade sizes.
- Manually or electronically operated.
- Available in aluminium and wooden louvre blades.



TYPES OF LOUVRE BLADE

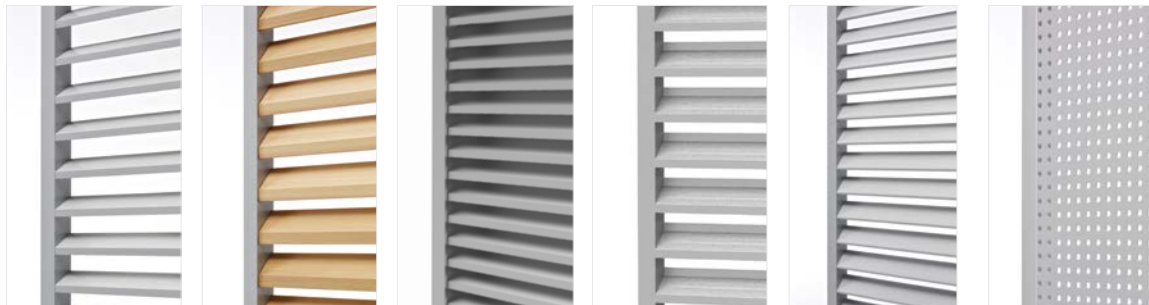

	Linear 55	Lux 40 Wood	30Z	40Z	60F	Perfo
LuxFrame 40/40	x	x	x	x	x	x
Louvre blade height (mm)	39	53	38	85	51	-
Louvre blade spacing (mm)	70	70	38	110	75	-
Louvre blade angle	33°	53°	34°	48°	55°	-

SECTIONAL DRAWINGS

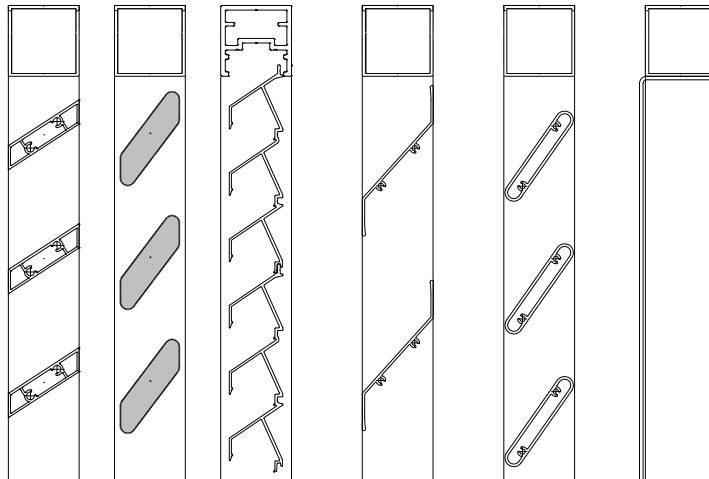

Linear 55 Lux 40 Wood 30Z 40Z 60F Perfo

→ DucoSlide Wood

DucoSlide Wood gives any façade a special aesthetic touch thanks to the perfect symbiosis of wood and aluminium. The wooden blades are installed invisibly within the aluminium frame and are also **quarter-cut**, which not only ensures more robust blades, but also prevents deformation. This feature, together with the sustainable and resilient **Western Red Cedar** wood (which also affords excellent protection against rot and weathering), the light weight and narrow panel width, makes DucoSlide Wood the perfect architectural solar shading system.



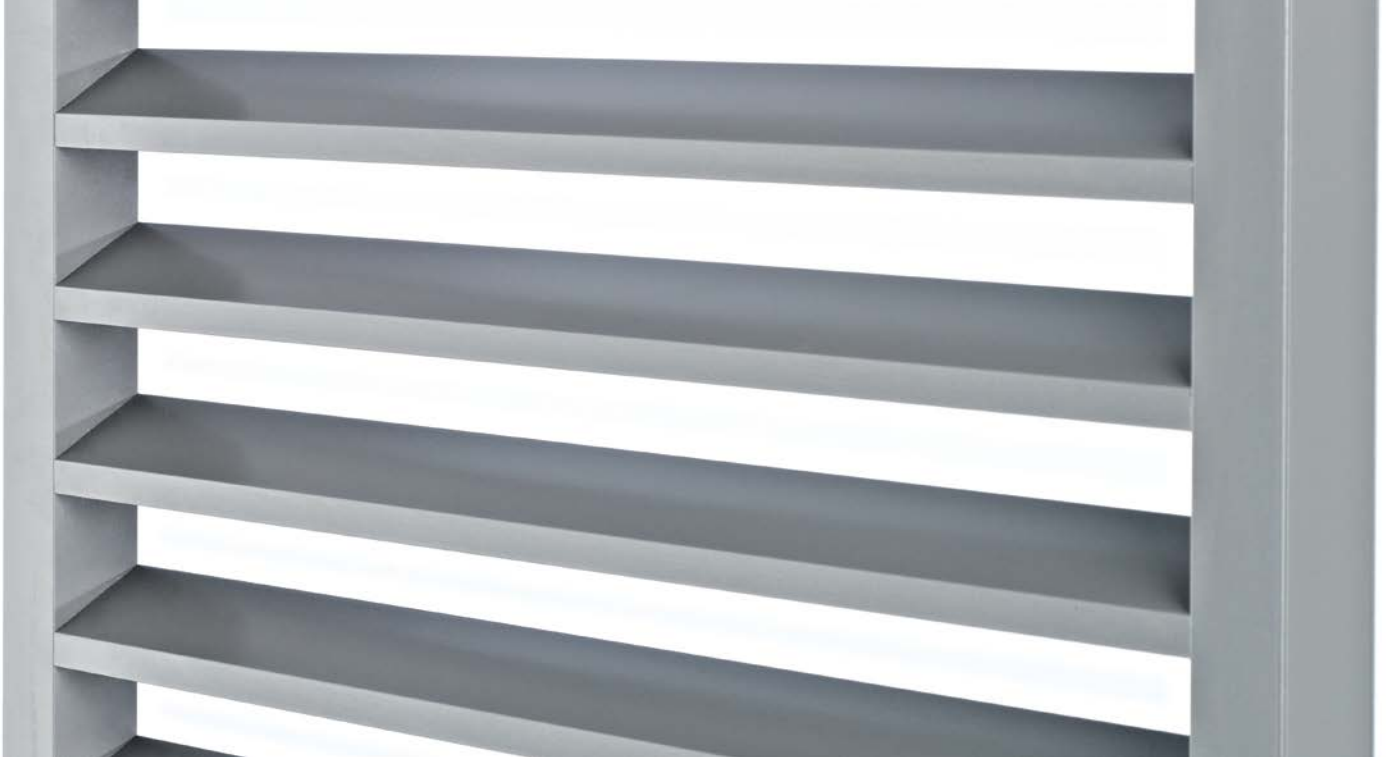

DucoSlide **LuxFrame**

(40/80 & 45/130 frame profiles)

DucoSlide LuxFrame 40/80 & 45/130 are permanent external solar shading systems with sliding panels. In these types, the different louvre blades are incorporated into a robust frame profile.

Frame types

- DucoSlide LuxFrame with 40/80 frame profile and fixed or adjustable louvre blades
- DucoSlide LuxFrame with 45/130 frame profile and fixed louvre blades

Sliding systems

- Single, symmetrical or telescopic
- Maximum degree of privacy.
- Choice of fixed or adjustable louvre blades.
- Various louvre blade sizes.
- Manually or electronically operated.
- Available in aluminium and wooden louvre blades.



TYPES OF LOUVRE BLADE



	Lux 80 Wood	Linear 115*	Ellips 150
LuxFrame 40/80	x	x	-
LuxFrame 45/130	-	-	x
Louvre blade height (mm)	65	83	108
Louvre blade spacing (mm)	100	145	190
Louvre blade angle	37°	39°	45°

SECTIONAL DRAWINGS

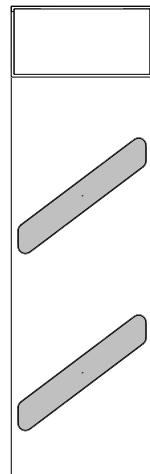

Lux 80 Wood

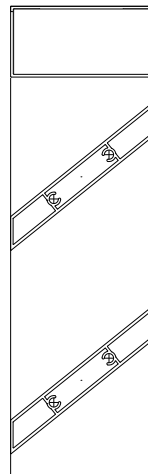

Linear 115

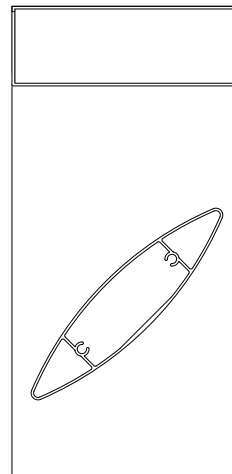

Ellips 150

→ DucoSlide Wood

DucoSlide Wood gives any façade a special aesthetic touch thanks to the perfect symbiosis of wood and aluminium. The wooden blades are installed invisibly within the aluminium frame and are also **quarter-cut**, which not only ensures more robust blades, but also prevents deformation. This feature, together with the sustainable and resilient **Western Red Cedar** wood (which also affords excellent protection against rot and weathering), the light weight and narrow panel width, makes DucoSlide Wood the perfect architectural solar shading system.



DucoSlide

Leuven (BE)







DucoSlide **SlimFrame**

(5/40 & 5/80 frame profiles)

DucoSlide SlimFrame is a permanent external solar shading system with sliding panels. Here, the louvre blades are installed at a fixed angle between the aesthetically refined and discrete side profiles.

Frame types

- DucoSlide SlimFrame with 5/40 frame profile and fixed louvre blades
- DucoSlide SlimFrame with 5/80 frame profile and fixed louvre blades

Sliding systems

- Single, symmetrical or telescopic
- Maximum degree of privacy.
- Various louvre blade sizes.
- Manually or electronically operated.



TYPES OF LOUVRE BLADE

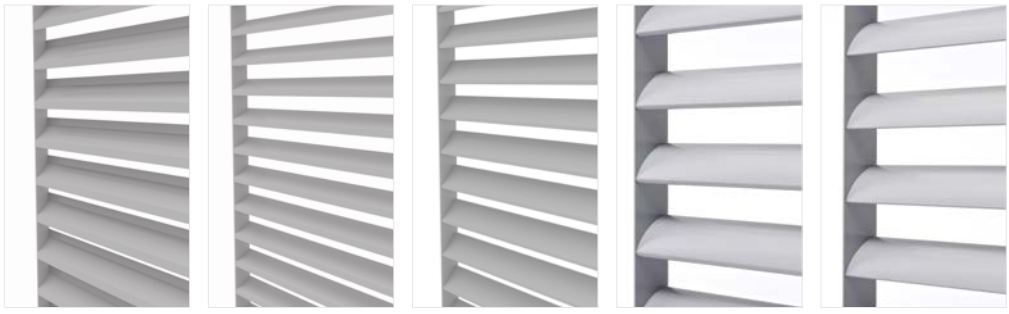

	40Z	Linear 55	60F	100D	Ellips 100
SlimFrame 5/40	x	x	x		
SlimFrame 5/80				x	x
Louvre blade height (mm)	85	39	51	76	72
Louvre blade spacing (mm)	110	70	75	140	140
Louvre blade angle	48°	33°	55°	45°	45°

SECTIONAL DRAWINGS

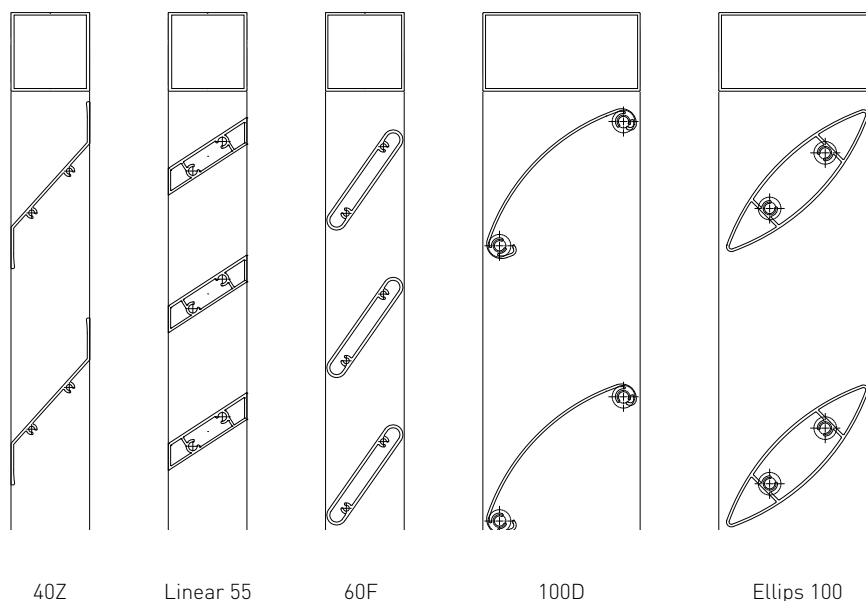

DucoSlide

Mechelen (BE)



SERVICE PLEASE!

To provide the best support for your project, you will find professional **sectional drawings**, **technical sheets**, **specification texts** and **assembly instructions** on our website www.duco.eu.

Discover what Duco can do for you.



Do you have a project? → Duco's project team will be happy to assist you in making a responsible and correct choice for solar shading in your specific projects. Among other things, the team uses its own software for the necessary calculations such as calculating strength, the correct spans and the attachment to the support structure. In addition, the ideal shadowing angles are calculated. Allowance is also made for the orientation of the façade, the path of the sun, etc.

BIM library → All the products in this library, produced in accordance with Dutch Revit Standards, are now freely available in Autodesk Revit MEP 2015/2016/2017/2018 format, 3D dwg (usable for all versions of AutoCad) and IFC. Download the library at www.duco.eu/bim-library.

Specification texts → Specification texts for all products are available on our website www.duco.eu.



TAILORED ADVICE

Duco offers tailored expertise & services for specifiers, and has a dedicated unit to advise and support architects, engineering offices and consultancies.

Duco works with reputable organisations such as the WTCB, the von Karman Institute, etc. Duco's knowledge and years of experience make it possible to offer an appropriate solution for each of your projects.

Any questions? Contact us at info@duco.eu or call +32 58 33 00 66 to receive personal advice!



A **SOLUTION**
FOR EVERY
PROJECT

DUCO
Ventilation & Sun Control